

# Instruction Manual

## 800 SERIES

**SPELLMAN  
HIGH VOLTAGE ELECTRONICS  
CORPORATION**

One Commerce Park  
Valhalla, New York, 10595

+1(914) 686-3600\* FAX: +1(914) 686-5424\*

E-mail: [sales@spellmanhv.com](mailto:sales@spellmanhv.com)

Website: [www.spellmanhv.com](http://www.spellmanhv.com)

USA

EUROPE

JAPAN

MEXICO



- **MODULAR BENCH TOP DESIGN**
- **115/220 VAC SWITCHABLE**
- **DIFFERENTIAL INPUT PROGRAMMING**

Spellman's Bertan brand of 825 Series high voltage power supplies provide well-regulated, fixed polarity outputs from 500 to 50kV that operate off a standard switch-selectable 115/230Vac input. The 825 Series is fully arc and short circuit protected. Excellent regulation specifications are featured along with outstanding stability performance.

### TYPICAL APPLICATIONS

- Projection Television
- X-ray Systems
- E-beam systems
- Capacitor Charging systems
- CPT/CRT testing

### SPECIFICATIONS

#### Input Voltage:

90 - 135Vac, ±10%, 50/60 Hertz @ 2 amps  
 185 - 265Vac, ±10%, 50/60 Hertz @ 1.5 amps  
 Input voltage is switch selectable

#### Output Voltage:

See "model selection" table

#### Output Polarity:

Positive or negative, specify at time of order

#### Output Current:

See "model selection" table

#### Voltage Regulation:

Line: ±(0.01% of setting + 0.01% of maximum) for ±10% input line change.

Load: ±(0.02% of setting + 0.02% of maximum) for FL-NL and NL-FL change.

#### Current Regulation:

Line: ±(0.05% of setting + 0.05% of maximum) for ±10% input line change. rated full current.

Load: ±(0.1% of setting + 0.1% of maximum) for 0 to maximum rated output voltage change.

#### Ripple:

0.1% of setting + 0.1% of maximum, peak-to-peak.

#### Temperature Coefficient:

Constant voltage operation:  
 ±(50ppm of setting + 50ppm of maximum)/°C

Constant current operation:  
 ±(100ppm of setting + 100ppm of maximum)/°C

#### Stability: (1/2 hour warm up)

Constant voltage operation:

±(0.01% of setting + 0.01% of maximum)/hr.; ±(0.02% of setting + 0.02% of maximum)/8 hrs.

Constant current operation: ±(0.02% of setting + 0.02% of maximum)/hr.; ±(0.04% of setting + 0.04% of maximum)/8 hrs.

#### Internal Controls:

Independent precision multi-turn potentiometers for voltage and current control. The resolution of each control is 0.05% of maximum. The potentiometers are screwdriver-adjustable and easily accessed.

#### Remote Programming:

Two independent 0 to 5Vdc inputs for 0 to maximum voltage and current outputs. Accuracy is ±(0.2% of setting + 0.2% of maximum). The programming input impedance is greater than 1MΩ. The program inputs are differential; this feature provides user-defined program voltage polarity and eliminates ground loops.

#### Voltage Monitor:

0 to +5Vdc proportional to 0 to maximum output high voltage. Accuracy is ±(0.2% of reading + 0.2% of maximum). The monitor output impedance is 10kΩ ±1%.

#### Current Monitor:

0 to +5Vdc proportional to 0 to maximum output current. Accuracy is ±(0.5% of reading + 0.2% of maximum). The monitor output impedance is 10kΩ ±1%.

#### Enable:

TTL compatible. Remote "high" signal disables high voltage, remote low enables high voltage. The enable input must be pulled low to allow operation of high voltage regardless of whether supply is in local or remote mode.

#### Operating Temperature

0°C to +50°C

#### Storage Temperature:

-40°C to +85°C

#### Humidity:

20% to 85% RH, non-condensing

#### Input Line Connector:

IEC320 EMI filter/input connector, a detachable line cord is provided

#### Interface Connector:

25 pin "D" connector, a mating connector is provided

**Output Connector:**

A detachable 10 foot (3 meter) HV cable is provided

**Cooling:**

Internal fan. Speed of fan is output power-dependent.

**Dimensions**

10.00" W X 3.19" H X 10.75" D  
(254mm X 81mm X 273mm)

**Weight:**

13 pounds (5.9kg)

DIMENSIONS: in.[mm]

**BOTTOM VIEW**

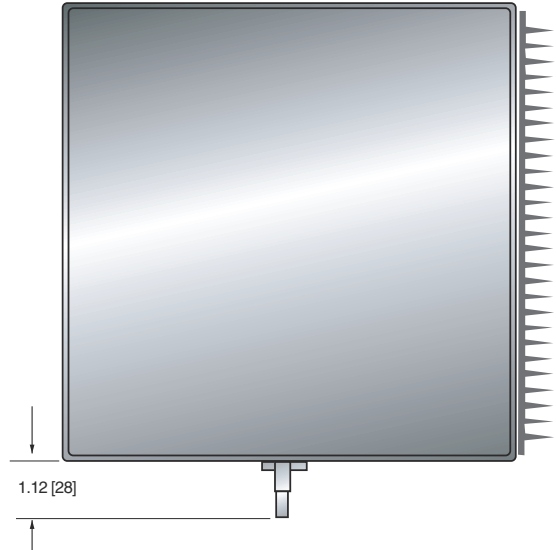

**MODEL SELECTION TABLE**

825 Series	Voltage	Current	Ripple
825-0.5N/P	0 to 500V	0 to 400mA	1V
825-1N/P	0 to 1kV	0 to 200mA	2V
825-1.5N/P	0 to 1.5kV	0 to 133mA	3V
825-3N/P	0 to 3kV	0 to 66mA	6V
825-5N/P	0 to 5kV	0 to 40mA	10V
825-10N/P	0 to 10kV	0 to 20mA	20V
825-20N/P	0 to 20kV	0 to 10mA	40V
825-30N/P	0 to 30kV	0 to 6.6mA	60V
825-50N/P	0 to 50kV	0 to 4mA	100V

**INTERFACE CONNECTOR**

PIN	SIGNAL	PARAMETERS
1	Vout Program Input (+)	0 to +5Vdc differential between pin 1 and pin 2 = 0 to 100% of rated Vout
2	Vout Program Input (-)	0 to +5Vdc differential between pin 1 and pin 2 = 0 to 100% of rated Vout
3	Vout Program Output	0 to +5Vdc = 0 to 100% rated voltage
4	Vout Monitor	0 to +5Vdc = 0 to 100% rated voltage, Zout = 10kΩ
5	Common (Vmon & Vref Return)	Ground
6	Vreference Output	+5.0VDC @ 10mA, maximum
7	NC	none
8	NC	none
9	NC	none
10	Logic Common	Ground
11	/Enable Input	TTL "0" enables high voltage output, defaults to disabled status if left unconnected
12	Remote/Enable Output	TTL "1" indicates high voltage is enable, TTL "0" indicates high voltage is disabled
13	V Mode and I/Mode Output	TTL "1" indicates voltage mode operation, TTL "0" indicates current mode operation,
14	Iout Program Input (+)	0 to +5Vdc differential between pin 14 and pin 15 = 0 to 100% of rated Iout
15	Iout Program Input (-)	0 to +5Vdc differential between pin 14 and pin 15 = 0 to 100% of rated Iout
16	Iout Program Output	0 to +5Vdc differential = 0 to 100% of rated current
17	Iout Monitor	0 to +5Vdc = 0 to 100% rated voltage, Zout = 10kΩ
18	Iout Common (Iout Monitor Return)	Ground
19	Analog Common	Ground
20	NC	none
21	NC	none
22	NC	none
23	NC	none
24	Polarity Status POS/NEG	TTL "1" indicates positive output, TTL "0" indicates negative output
25	NC	none

The "/" in front of a parameter indicates the function is active when low.

**FRONT VIEW**

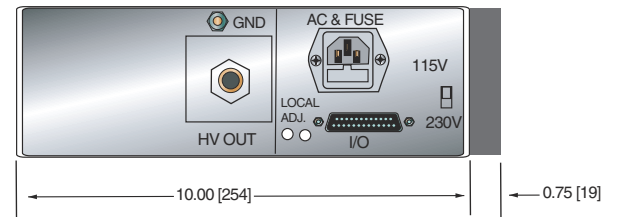

**SIDE VIEW**

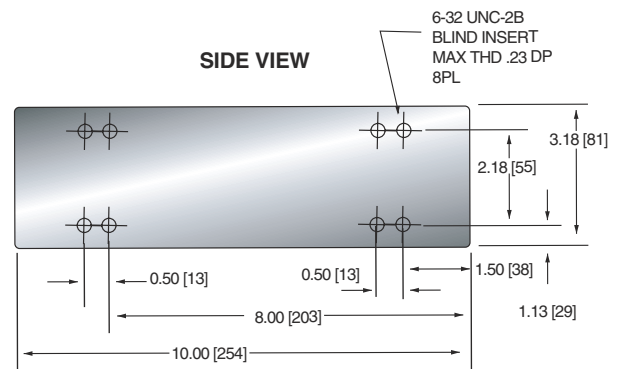



- **MODULAR BENCH TOP DESIGN**
- **115/220 VAC SWITCHABLE**
- **DIFFERENTIAL INPUT PROGRAMMING**

Spellman's Bertan brand of 835 Series high voltage power supplies provide well-regulated, fixed polarity outputs from 500 to 50kV that operate off a standard switch-selectable 115/230Vac input. The 835 Series is fully arc and short circuit protected. Excellent regulation specifications are featured along with outstanding stability performance.

### TYPICAL APPLICATIONS

Projection Television  
X-ray Systems  
E-beam systems  
Capacitor Charging systems  
CPT/CRT testing

### SPECIFICATIONS

#### Input Voltage:

90 - 135Vac,  $\pm 10\%$ , 50/60 Hertz @ 6 amps  
185 - 265Vac,  $\pm 10\%$ , 50/60 Hertz @ 3 amps  
Input voltage is switch selectable

#### Output Voltage:

See "model selection" table

#### Output Polarity:

Positive or negative, specify at time of order

#### Output Current:

See "model selection" table

#### Voltage Regulation:

Line:  $\pm(0.01\%$  of setting + 0.01% of maximum)  
for  $\pm 10\%$  input line change.

Load:  $\pm(0.02\%$  of setting + 0.02% of maximum)  
for FL-NL and NL-FL change.

#### Current Regulation:

Line:  $\pm(0.05\%$  of setting + 0.05% of maximum)  
for  $\pm 10\%$  input line change. rated full current.

Load:  $\pm(0.1\%$  of setting + 0.1% of maximum) for  
0 to maximum rated output voltage change.

#### Ripple:

0.1% of setting + 0.1% of maximum, peak-to-peak.

#### Temperature Coefficient:

Constant voltage operation:  
 $\pm(50\text{ppm}$  of setting + 50ppm of maximum)/ $^{\circ}\text{C}$

Constant current operation:  
 $\pm(100\text{ppm}$  of setting + 100ppm of maximum)/ $^{\circ}\text{C}$

#### Stability: (1/2 hour warm up)

Constant voltage operation:

$\pm(0.01\%$  of setting + 0.01% of maximum)/hr.;  $\pm(0.02\%$  of setting + 0.02% of maximum)/8 hrs.

Constant current operation:  $\pm(0.02\%$  of setting + 0.02% of maximum)/hr.;  $\pm(0.04\%$  of setting + 0.04% of maximum)/8 hrs.

#### Internal Controls:

Independent precision multi-turn potentiometers for voltage and current control. The resolution of each control is 0.05% of maximum. The potentiometers are screwdriver-adjustable and easily accessed.

#### Remote Programming:

Two independent 0 to 5Vdc inputs for 0 to maximum voltage and current outputs. Accuracy is  $\pm(0.2\%$  of setting + 0.2% of maximum). The programming input impedance is greater than 1M $\Omega$ . The program inputs are differential; this feature provides user-defined program voltage polarity and eliminates ground loops.

#### Voltage Monitor:

0 to +5Vdc proportional to 0 to maximum output high voltage. Accuracy is  $\pm(0.2\%$  of reading + 0.2% of maximum). The monitor output impedance is 10k $\Omega$   $\pm 1\%$ .

#### Current Monitor:

0 to +5Vdc proportional to 0 to maximum output current. Accuracy is  $\pm(0.5\%$  of reading + 0.2% of maximum). The monitor output impedance is 10k $\Omega$   $\pm 1\%$ .

#### Enable:

TTL compatible. Remote "high" signal disables high voltage, remote low enables high voltage. The enable input must be pulled low to allow operation of high voltage regardless of whether supply is in local or remote mode.

#### Operating Temperature

0 $^{\circ}\text{C}$  to +50 $^{\circ}\text{C}$

#### Storage Temperature:

-40 $^{\circ}\text{C}$  to +85 $^{\circ}\text{C}$

#### Humidity:

20% to 85% RH, non-condensing

#### Input Line Connector:

IEC320 EMI filter/input connector, a detachable line cord is provided

#### Interface Connector:

25 pin "D" connector, a mating connector is provided

**Output Connector:**

A detachable 10 foot (3 meter) HV cable is provided.

**Cooling:**

Internal fan. Speed of fan is output power-dependent.

**Dimensions**

10.00" W X 5.00" H X 11.00" D  
(254mm X 127mm X 279mm)

**Weight:**

18 pounds (8.2kg)

**MODEL SELECTION TABLE**

835 Series	Voltage	Current	Ripple
835-0.5N/P	0 to 500V	0 to 600mA	1V
835-1N/P	0 to 1kV	0 to 300mA	2V
835-1.5N/P	0 to 1.5kV	0 to 200mA	3V
835-3N/P	0 to 3kV	0 to 100mA	6V
835-5N/P	0 to 5kV	0 to 60mA	10V
835-10N/P	0 to 10kV	0 to 30mA	20V
835-20N/P	0 to 20kV	0 to 15mA	40V
835-30N/P	0 to 30kV	0 to 10mA	60V
835-50N/P	0 to 50kV	0 to 6mA	100V

**INTERFACE CONNECTOR**

PIN	SIGNAL	PARAMETERS
1	Vout Program Input (+)	0 to +5Vdc differential between pin 1 and pin 2 = 0 to 100% of rated Vout
2	Vout Program Input (-)	0 to +5Vdc differential between pin 1 and pin 2 = 0 to 100% of rated Vout
3	Vout Program Output	0 to +5Vdc = 0 to 100% rated voltage
4	Vout Monitor	0 to +5Vdc = 0 to 100% rated voltage, Zout = 10kΩ
5	Common (Vmon & Vref Return)	Ground
6	Vreference Output	+5.0VDC @ 10mA, maximum
7	NC	none
8	NC	none
9	NC	none
10	Logic Common	Ground
11	/Enable Input	TTL "0" enables high voltage output, defaults to disabled status if left unconnected
12	Remote/Enable Output	TTL "1" indicates high voltage is enable, TTL "0" indicates high voltage is disabled
13	V Mode and I/Mode Output	TTL "1" indicates voltage mode operation, TTL "0" indicates current mode operation,
14	Iout Program Input (+)	0 to +5Vdc differential between pin 14 and pin 15 = 0 to 100% of rated Iout
15	Iout Program Input (-)	0 to +5Vdc differential between pin 14 and pin 15 = 0 to 100% of rated Iout
16	Iout Program Output	0 to +5Vdc differential = 0 to 100% of rated current
17	Iout Monitor	0 to +5Vdc = 0 to 100% rated voltage, Zout = 10kΩ
18	Iout Common (Iout Monitor Return)	Ground
19	Analog Common	Ground
20	NC	none
21	NC	none
22	NC	none
23	NC	none
24	Polarity Status POS/NEG	TTL "1" indicates positive output, TTL "0" indicates negative output
25	NC	none

The "/" in front of a parameter indicates the function is active when low.

DIMENSIONS: in.[mm]

**BOTTOM VIEW**

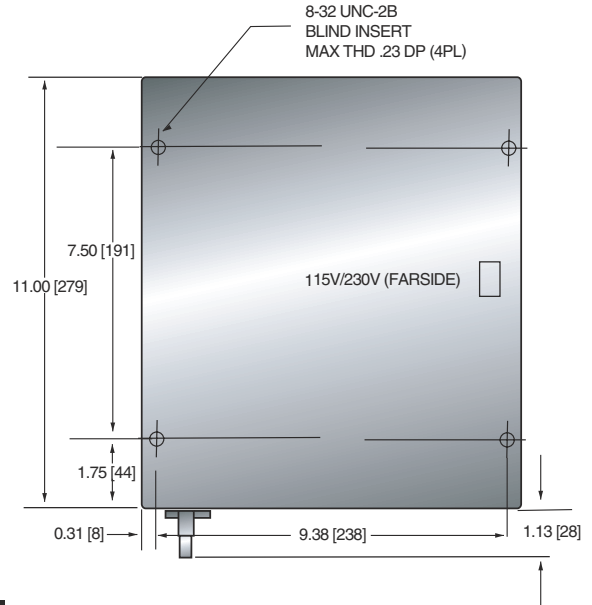

**FRONT VIEW**

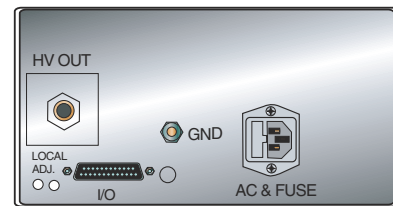

**SIDE VIEW**

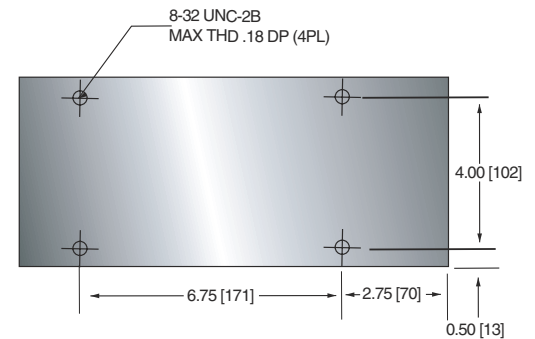

Up to 5kV only



USA +1-631-630-3000  
UK +44 (0)1798 877000  
JAPAN +81 (0)48-447-6500  
CHINA +86 (0)512-67630010

FAX: +1-631-435-1620  
FAX: +44 (0)1798 872479  
FAX: +81 (0)48-447-6501  
FAX: +86 (0)512-67630030

e-mail: sales@spellmanhv.com  
www.spellmanhv.com

128058-001 REV.C

Spellman High Voltage is an ISO 9001:2000 and ISO 14001:2004 registered company

## IMPORTANT SAFETY PRECAUTIONS

### SAFETY

THIS POWER SUPPLY GENERATES VOLTAGES THAT ARE DANGEROUS AND MAY BE FATAL.  
OBSERVE EXTREME CAUTION WHEN WORKING WITH THIS EQUIPMENT.

High voltage power supplies must always be grounded.

Do not touch connections unless the equipment is off and the Capacitance of both the load and power supply is discharged.

Allow five minutes for discharge of internal capacitance of the power supply.

Do not ground yourself or work under wet or damp conditions.

### SERVICING SAFETY

Maintenance may require removing the instrument cover with the power on.

Servicing should be done by qualified personnel aware of the electrical hazards.

**WARNING** note in the text call attention to hazards in operation of these units that could lead to possible injury or death.

**CAUTION** notes in the text indicate procedures to be followed to avoid possible damage to equipment.

Copyright © 2000, Spellman High Voltage Electronics Corporation. All Rights Reserved.  
This information contained in this publication is derived in part from proprietary and patent data. This information has been prepared for the express purpose of assisting operating and maintenance personnel in the efficient use of the model described herein, and publication of this information does not convey any right to reproduce it or to use it for any purpose other than in connection with installation, operation, and maintenance of the equipment described.

# WICHTIGE SICHERHEITSHINWEISE

## SICHERHEIT

DIESES HOCHSPANNUNGSNETZTEIL ERZEUGT LEBENSGEFÄHRLICHE HOCHSPANNUNG.  
SEIN SIE SEHR VORSICHTIG BEI DER ARBEIT MIT DIESEM GERÄT.

Das Hochspannungsnetzteil muß immer geerdet sein.

Berühren Sie die Stecker des Netzteiles nur, wenn das Gerät ausgeschaltet ist und die elektrischen Kapazitäten des Netzteiles und der angeschlossenen Last entladen sind.

Die internen Kapazitäten des Hochspannungsnetzteiles benötigen ca. 5 Minuten, um sich zu entladen.

Erden Sie sich nicht, und arbeiten Sie nicht in feuchter oder nasser Umgebung.

## SERVICESICHERHEIT

Notwendige Reparaturen können es erforderlich machen, den Gehäusedeckel während des Betriebes zu entfernen.

Reparaturen dürfen nur von qualifiziertem, eingewiesenem Personal ausgeführt werden.

“WARNING” im folgenden Text weist auf gefährliche Operationen hin, die zu Verletzungen oder zum Tod führen können.

“CAUTION” im folgenden Text weist auf Prozeduren hin, die genauestens befolgt werden müssen, um eventuelle Beschädigungen des Gerätes zu vermeiden.

# PRECAUTIONS IMPORTANTES POUR VOTRE SECURITE

## CONSIGNES DE SÉCURITÉ

CETTE ALIMENTATION GÉNÈRE DES TENSIONS QUI SONT DANGEUREUSES ET PEUVENT ÊTRE FATALES.  
SOYEZ EXTRÊMEMENT VIGILANTS LORSQUE VOUS UTILISEZ CET ÉQUIPEMENT.

Les alimentations haute tension doivent toujours être mises à la masse.

Ne touchez pas les connectiques sans que l'équipement soit éteint et que la capacité à la fois de la charge et de l'alimentation soient déchargées.

Prévoyez 5 minutes pour la décharge de la capacité interne de l'alimentation.

Ne vous mettez pas à la masse, ou ne travaillez pas sous conditions mouillées ou humides.

## CONSIGNES DE SÉCURITÉ EN CAS DE REPARATION

La maintenance peut nécessiter l'enlèvement du couvercle lorsque l'alimentation est encore allumée.

Les réparations doivent être effectuées par une personne qualifiée et connaissant les risques électriques.

Dans le manuel, les notes marquées « **WARNING** » attire l'attention sur les risques lors de la manipulation de ces équipements, qui peuvent entraîner de possibles blessures voire la mort.

Dans le manuel, les notes marquées « **CAUTION** » indiquent les procédures qui doivent être suivies afin d'éviter d'éventuels dommages sur l'équipement.



## IMPORTANTI PRECAUZIONI DI SICUREZZA

### SICUREZZA

QUESTO ALIMENTATORE GENERA TENSIONI CHE SONO PERICOLOSE E POTREBBERO ESSERE MORTALI.  
PONI ESTREMA CAUTELA QUANDO OPERI CON QUESTO APPARECCHIO.

- Gli alimentatori ad alta tensione devono sempre essere collegati ad un impianto di terra.
- Non toccare le connessioni a meno che l'apparecchio sia stato spento e la capacità interna del carico e dell'alimentatore stesso siano scariche.
- Attendere cinque minuti per permettere la scarica della capacità interna dell'alimentatore ad alta tensione.
- Non mettere a terra il proprio corpo oppure operare in ambienti bagnati o saturi d'umidità.

### SICUREZZA NELLA MANUTENZIONE.

- Manutenzione potrebbe essere richiesta, rimuovendo la copertura con apparecchio acceso.
- La manutenzione deve essere svolta da personale qualificato, coscio dei rischi elettrici.
- Attenzione alle **AVVERTENZE** contenute nel manuale, che richiamano all'attenzione ai rischi quando si opera con tali unità e che potrebbero causare possibili ferite o morte.
- Le note di **CAUTELA** contenute nel manuale, indicano le procedure da seguire per evitare possibili danni all'apparecchio.

## Table of Contents

### **I. GENERAL INFORMATION – Scope of Manual**

1.1	Description .....	2
1.2	Electrical Specifications .....	2
1.3	Options (OEM Applications Only).....	3
1.4	Custom Models (OEM Applications Only) .....	3
1.5	Safety Terms.....	3

### **II. INSTALLATION AND OPERATION**

2.1	Initial Inspection .....	4
2.2	Preparation for Use .....	4
2.3	Mechanical Installation .....	4
2.4	Voltage and Current Control .....	4
2.5	Internal Controls.....	4
2.6	Remote Programming .....	5
2.7	Remote Monitoring .....	5
2.8	Connections and Terminals .....	5
	Table 2.1 – Fuse Specifications .....	5
	Table 2.2 – Remote Connector Pin Designations .....	5

### **III. THEORY OF OPERATION**

3.1	Switching Supply Overview.....	6
3.2	Switching Supply Power Conversion .....	6
3.3	Switching Supply Output.....	6

### **IV. MAINTENANCE**

4.1	General .....	7
4.2	Cleaning.....	7
4.3	Calibration Services .....	7

THE DATA CONTAINED IN THIS MANUAL IS SUBJECT TO CHANGE WITHOUT NOTICE. WRITTEN PERMISSION FROM SPELLMAN HIGH VOLTAGE IS REQUIRED PRIOR TO THE REPRODUCTION OF ANY TECHNICAL DATA CONTAINED IN THIS MANUAL.

## SECTION 1 - GENERAL INFORMATION

### 1.0 SCOPE OF MANUAL

The Series 825 and 835 are regulated precision laboratory high voltage power supplies. These supplies provide high performance and value in many applications including detectors, projection CRT's, X-ray, electrophoresis, microwave and capacitor charging.

### 1.1 DESCRIPTION

The Series 825 and 835 are three families of high efficiency switchmode, fixed output polarity, modular high voltage power supplies that feature constant voltage and constant current operation with automatic crossover. A wide range of output voltages, up to 50kV, is available. Designed for safety and reliability, all models include a safety interlock, soft start and power interrupt trip, as well as arc, short circuit and open circuit protection. The units are fully enclosed and designed for system or bench top use. They operate off of standard line input of 115/230 Vac (switch selectable) 50-60 Hz. The output voltage and output current are independently controlled by internal multi-turn potentiometers. Remote analog voltage or resistance programming of both the output voltage and current is included in all models. Analog monitor outputs are also provided for remote monitoring of both the high voltage and current outputs. A front panel LED indicator provides power ON status.

### 1.2 ELECTRICAL SPECIFICATIONS

**Input:**

90-135Vac @ 2A (815), 5A (825), 6A (835), 50-60Hz.

185 - 265Vac @ 1.5A (815), 2.5A (825), 3A (835), 50-60Hz.

**Voltage Regulation:** (0.01% of setting + 0.01% of maximum) for 10% input line change. (0.02% of setting + 0.02% of maximum) for FL-NL and NL-FL change

**Current Regulation:** (0.05% of setting + 0.05% of maximum) for 10% input line change. (0.1% of setting + 0.1% of maximum) for 0 to maximum rated output voltage change.

**Output Voltage/Current Capability:**

825 / 835		MAXIMUM OUTPUT CURRENT	
MODEL SUFFIX	OUTPUT VOLTAGE	200W SERIES 825	300W SERIES 835
-0.5N, P	0 to 500V	0 to 400mA	0 to 600mA
-1N, P	0 to 1KV	0 to 100mA	0 to 100mA
-1.5N, P	0 to 1.5kV	0 to 133mA	0 to 200mA
-3N, P	0 to 3kV	0 to 66mA	0 to 100mA
-5N, P	0 to 5kV	0 to 40mA	0 to 60mA
-10N, P	0 to 10kV	0 to 20mA	0 to 30mA
-20N, P	0 to 20kV	0 to 10mA	0 to 15mA
-30N, P	0 to 30kV	0 to 6.6mA	0 to 10mA
-50N, P	0 to 50kV	0 to 4mA	0 to 6mA

To obtain appropriate part number, select series, then append model suffix and polarity suffix.

**Polarity:** The output is fixed polarity, either positive or negative (suffix P or N).

**Ripple:** 0.1% of setting + 0.1% of maximum, peak to-peak. Lower ripple available on many models. Consult factory for details.

**Temperature Coefficient:** *Constant voltage operation:* ± (50ppm of setting + 50ppm of maximum)/ °C *Constant current operation:* ± (100ppm of setting + 100ppm of maximum)/ °C.

**Stability (after 1/2 hr. warm-up):** *Constant Voltage Operation:* ± (0.01% of setting + 0.01 % of maximum)/hr; ±(0.02% of setting + 0.02% of maximum)/8 hrs.

*Constant Current Operation:* ± (0.02% of setting + 0.02% of maximum)/hr; ±(0.04% of setting + 0.04% of maximum)/8 hrs.

**Efficiency:** Better than 80%.

**Internal Controls:** The output voltage and current can be set by the I/V potentiometer controls on the front panel. Two continuous multi-turn precision potentiometers directly dial the voltage and the current. The resolution of each control is 0.05% of maximum.

**Voltage Monitor:** 0 to 5Vdc proportional to 0 to maximum output high voltage. Accuracy is  $\pm(0.2\%$  of reading  $+0.2\%$  of maximum). The monitor output impedance is 10 kilohms  $\pm 1\%$ .

**Current Monitor:** 0 to +5Vdc proportional to 0 to maximum output current. Accuracy is  $\pm(0.5\%$  of reading  $+0.2\%$  of maximum). The monitor output impedance is 10 kilohms  $\pm 1\%$ .

**Interlock:** TTL compatible remote signal disables (high), enables (low) the high voltage output. The enable input must be pulled low to allow operation of high voltage, regardless of whether supply is in local or remote mode.

**Protection:** Arc, short-circuit and open circuit protection, self-restoring.

**Size:**

Series 825: 3.19" H x 10" W x 10.75" D (81 x 254 x 273 mm)

Series 835: 5" H x 10" W x 11" D (127 x 254 x 279 mm)

**Weight:**

Series 825: 13 lbs (5.9 kg)

Series 835: 18 lbs (8.2 kg)

**Power Input Connector:** 3-wire IEC line cord receptacle. Detachable line cord for 115 Vac line is included.

**Low Voltage I/O Connector:** Standard 25 pin "D" type connector for all remote control and monitor functions. The mating connector is provided.

**Cooling:** Internal fan.

### 1.3 OPTIONS (OEM APPLICATIONS ONLY)

Additional functions such as programmable overload detection and response. The interface performs the necessary conversions to allow direct user-friendly operation. The operating instructions provide complete set-up and programming information. Software is also available to assist in standard operation environments. Application specific software can also be provided.

**10V Programming / Monitoring (OEM APPLICATIONS ONLY):** 0 to 10Vdc input for 0 to maximum voltage and current output. 0 to 10Vdc proportional monitors for voltage and current output.

### 1.4 CUSTOM MODELS (OEM APPLICATIONS ONLY)

The Series 825/835 power supply design can be economically and quickly modified to satisfy custom applications. Other output voltage and/or current ratings, digital programming or special mechanical constraints are some of the varied requirements, which can be satisfied. Multi-output units combining the features of the Series 825/835 and other Spellman high voltage power supplies can be provided. Contact Spellman Sales Engineering for a responsive review of your application.

Specifications subject to change without notice.

### 1.5 SAFETY TERMS

The **WARNING** used in this manual explains dangers that could result in personal injury or death. The **CAUTION** used in this manual explains hazards that could damage the instrument.

## SECTION 2 - INSTALLATION & OPERATION

### 2.1 INITIAL INSPECTION

Inspect the package exterior for evidence of damage due to handling in transit. Notify the carrier and Spellman immediately if damage is evident. Do not destroy or remove any of the packing material used in a damaged shipment. After unpacking, inspect the panel and chassis for visible damage.

Fill out and mail the Warranty Registration card accompanying the unit. For warranty information refer to the Warranty section of this manual.

### 2.2 PREPARATION FOR USE

**WARNING!** *This unit produces hazardous voltage. Do not apply line voltage input unless adequate ground is connected to the unit and the high voltage output has been properly connected.*

#### **Front Panel Controls:**

- a) Check the input voltage rating on the front panel of the supply and make certain that this is the rating of the available power source.
  - b) The chassis of the high voltage power supply must be grounded to earth ground using the lug provided on the front panel of the unit.
  - c) A three wire grounding system is provided for connecting to the AC supply.
  - d) Attach the high voltage output connector / cable to the bulkhead receptacle on the front panel of the power supply.
  - e) Prior to initial turn-on, rotate the high voltage potentiometer ( $V_o$ ) and the current potentiometer ( $I_o$ ) fully counter-clockwise to the zero voltage and current positions respectively (Local Mode).
  - f) Check that the DB25 connector (I/O) is wired in accordance with the mode of operation desired.
  - g) The input cable may now be plugged into the AC power source.
  - h) To enable the high voltage output you must apply a low logic signal to Pin 11 of the DB25 connector.
- i) To disable the high voltage output Pin 11 of the DB25 connector must be either open or you must apply a high logic signal.
  - j) For this unit to operate properly the  $V_{O/I/O}$  potentiometers MUST be set to something other than zero. This will allow the unit to supply both voltage and current. This unit can operate either as a current source or a voltage source. To operate as a voltage source the unit should be set to the desired voltage and the current setting must be set so that it will not limit the current. To operate the unit as a current source the unit should be set to the desired current and the voltage setting must be set so that it does not limit the voltage.

**WARNING!** *After turnoff, do not handle the load until the capacitance has been discharged. Load capacitance may be discharged by shorting to ground.*

### 2.3 MECHANICAL INSTALLATION

Space must be allowed for access to cable connections. Units are fully enclosed and are suitable for bench, tabletop, or OEM operation.

### 2.4 VOLTAGE AND CURRENT CONTROL

The Series 800 power supplies have three modes of controlling the output voltage and current available to the user. The output voltage and current can be controlled from either an external voltage source, the internal potentiometers. When wired for remote operation the internal controls have no effect on the output voltage or current and therefore need not be turned to zero. When in local mode, the internal controls determine the output voltage and current.

### 2.5 INTERNAL CONTROLS

The output voltage and current can be set by the I/V potentiometer controls on the front panel. Two continuous multi-turn precision potentiometers directly dial the voltage and the current. The resolution of each control is 0.05% of maximum. The potentiometers are screwdriver adjustable and easily accessed. For local current and voltage control the following pins must be shorted:

**Pins 1 to 3, pins 2 to 5, pins 14 to 16, pins 15 to 18**

## 2.6 REMOTE PROGRAMMING

An output voltage and current can be remotely programmed from either an external differential voltage source or with an external potentiometer from the internal reference voltage source. A 0 to 5Vdc differential programming voltage applied to Pins 1 and 2 of the Programming / Monitor connector (I/O) on the front panel will remotely program the high voltage output from zero to maximum output. A 0 to 5Vdc differential programming voltage applied to Pins 14 and 15 of the Programming / Monitor connector on the front panel will remotely program the output current from zero to maximum.

## 2.7 REMOTE MONITORING

Remote voltage and current monitoring signals are available at Pins 4 and 17 respectively of the Programming / Monitor connector. A 0 to 5Vdc voltmeter may be used to monitor both voltage (Pin 4) and current (Pin 17) for the full output range. Both outputs are positive polarity regardless of the actual polarity of the output voltage.

## 2.8 CONNECTIONS AND TERMINALS

### Ground:

Ground is connected to the case on all models.

### Fuse:

The fuse is installed in AC line connector. Refer to the following table for fuse size.

**TABLE 2.1**  
**Fuse Specifications**

INPUT VOLTAGE	825	835
90-135 Vac	5A	6A
185-265 Vac	2.5A	3A

### Line Voltage Selector:

The line voltage selector selects the appropriate line voltage (1 15Vac or 230Vac).

### Power Input Connector:

3-wire IEC line cord receptacle. A detachable line cord is included.

### HV Output Connector:

The High Voltage output connector is located on the front panel. Refer to the Specifications section for detailed information on the high voltage connector and its mating connector.

### Remote Connector:

A 25 pin "D-Type" connector provides remote programming and monitoring of the power supply. A remote enable is also provided and is required to enable high voltage operation. Refer to Table 2.2 for pin designations. When utilizing the remote capabilities of this unit it must be noted that grounding is extremely important.

**TABLE 2.2**  
**Remote Connector Pin Designations**

PIN	FUNCTION
1	$V_{OUT}$ Program Input (+)
2	$V_{OUT}$ Program Input (-)
3	$V_{OUT}$ Program Output
4	$V_{OUT}$ Program Monitor
5	Common ( $V_{MON}$ & $V_{REF}$ Return)
6	+5Vdc Reference Output
7	N.C.
8	N.C.
9	N.C.
10	Logic Common
11	ENABLE Input
12	ENABLE Remote Output
13	$V_{MODE}$ / $I_{MODE}$ Output
14	$I_{OUT}$ Program Input (+)
15	$I_{OUT}$ Program Input (-)
16	$I_{OUT}$ Program Output
17	$I_{OUT}$ Monitor
18	Common ( $I_{MON}$ Return)
19	Analog Common
20	N.C.
21	N.C.
22	N.C.
23	N.C.
24	Polarity Status POS / NEG
25	N.C.

## **SECTION 3 - THEORY OF OPERATION**

### **3.1 SWITCHING SUPPLY OVERVIEW**

Spellman switching supplies use control and monitoring circuits similar to Spellman's line of linear supplies. Differences occur in the techniques used to generate the output power and in the control circuits after the error amplifier. Switching supplies contain additional protection and other ancillary circuits. The techniques Spellman uses for switching supplies allow for control over an extremely wide range of output current and voltage.

### **3.2 SWITCHING SUPPLY POWER CONVERSION**

Spellman uses an off-line configuration where the ac line is rectified and smoothed by a capacitive filter. The rectified voltage is converted to an ac voltage by a half bridge inverter. The inverter output waveform is an approximate 30kHz sinusoid. Average current control mode is used. The main loop controls duty cycle of the inverter as a function of output voltage and current to maintain constant output voltage or current. The inverter is quasi resonant in that switching takes place at approximately zero current to reduce EMI and switching losses. The ac voltage from the inverter is fed to the primary of the step-up transformer. As in the linear supply, the step-up transformer output is rectified or voltage multiplied, and filtered in the high voltage assembly.

### **3.3 SWITCHING SUPPLY OUTPUT CONTROL**

The high voltage dc output is sensed by a high voltage divider, and fed through a sense amplifier to the main error amplifier. The error amplifier compares the programming voltage with the sense voltage, and outputs the necessary signal voltage to maintain the desired constant high voltage output. A second error amplifier then compares the error voltage with a signal that is representative of the output average current. The output of the second error amplifier is fed to the PWM (Pulse Width Modulator) which controls the pulse width of the half bridge inverter.

Any change detected in the output voltage by the sense amplifier is fed to the first error amplifier and in turn, to the second amplifier for correction of pulse width. The second error amplifier maintains constant current in the inverter transformer primary, which is approximately proportional to the high

voltage output current. The power supply can work as a voltage or current source, depending on the programming and load conditions. The crossover from current source to voltage source, or vice versa, is automatic.

## **SECTION 4 - MAINTENANCE**

### **4.1 GENERAL**

The Series 825 and 835 instruments should not require any maintenance. They are designed for reliable, trouble free operation. If any question should arise, contact the Spellman Customer Service Department for assistance or return authorization. It is suggested that the unit be returned to the factory if service should become necessary.

### **4.2 CLEANING**

Cleaning of the power supply should *only* be performed with the supply disconnected from the ac power source. A soft cloth moistened with conventional ammonia-based cleaning agents will suffice for all exposed surfaces. The outer shell of

the HV connector should be cleaned with isopropyl alcohol.

### **4.3 CALIBRATION SERVICES**

Your Spellman high voltage power supply is designed to provide many years of reliable service. For a nominal charge it can be returned to the factory for calibration and certification to its original specification. For traceability, a certificate will be issued, identifying the serial number of the unit calibrated and all test equipment used to perform the calibration. All measurements are traceable to the National Institute of Standards and Technology (NIST). Calibration is guaranteed from 1 year of issuance. Contact the factory at 1-914-686-3600 or your local sales representative for additional details



# **SPELLMAN HIGH VOLTAGE ELECTRONICS**

## **WARRANTY**

**Spellman** High Voltage Electronics ("**Spellman**") warrants that all power supplies it manufactures will be free from defects in materials and factory workmanship, and agrees to repair or replace, without charge, any power supply that under normal use, operating conditions and maintenance reveals during the warranty period a defect in materials or factory workmanship. The warranty period is twelve (12) months from the date of shipment of the power supply. With respect to standard SL power supplies (not customized) the warranty period is thirty-six (36) months from the date of shipment of the power supply.

This warranty does not apply to any power supply that has been:

- Disassembled, altered, tampered, repaired or worked on by persons unauthorized by **Spellman**;
- subjected to misuse, negligent handling, or accident not caused by the power supply;
- installed, connected, adjusted, or used other than in accordance with the original intended application and/or instructions furnished by **Spellman**.

THE FOREGOING WARRANTY IS IN LIEU OF ALL OTHER WARRANTIES, EXPRESS OR IMPLIED, INCLUDING THOSE OF MERCHANTABILITY OR FITNESS FOR A PARTICULAR PURPOSE.

The buyer's sole remedy for a claimed breach of this warranty, and **Spellman's** sole liability is limited, at **Spellman's** discretion, to a refund of the purchase price or the repair or replacement of the power supply at **Spellman's** cost. The buyer will be responsible for shipping charges to and from **Spellman's** plant. The buyer will not be entitled to make claim for, or recover, any anticipatory profits, or incidental, special or consequential damages resulting from, or in any way relating to, an alleged breach of this warranty.

No modification, amendment, supplement, addition, or other variation of this warranty will be binding unless it is set forth in a written instrument signed by an authorized officer of **Spellman**.

### **Factory Service Procedures**

For an authorization to ship contact **Spellman's** Customer Service Department. Please state the model and serial numbers, which are on the plate on the rear panel of the power supply and the reason for return. A Return Material Authorization Code Number (RMA number) is needed from **Spellman** for all returns. The RMA number should be marked clearly on the outside of the shipping container. Packages received without an RMA Number may delay return of the product. The buyer shall pay shipping costs to and from **Spellman**. Customer Service will provide the Standard Cost for out-of-warranty repairs. A purchase order for this amount is requested upon issuance of the RMA Number (in-warranty returns must also be accompanied by a "zero-value" purchase order). A more detailed estimate may be made when the power supply is received at **Spellman**. In the event that the cost of the actual repair exceeds the estimate, **Spellman** will contact the customer to authorize the repair.

### **Factory Service Warranty**

**Spellman** will warrant for three (3) months or balance of product warranty, whichever is longer, the repaired assembly/part/unit. If the same problem shall occur within this warranty period **Spellman** shall undertake all the work to rectify the problem with no charge and/or cost to the buyer. Should the cause of the problem be proven to have a source different from the one that has caused the previous problem and/or negligence of the buyer, **Spellman** will be entitled to be paid for the repair.

### **Spellman Worldwide Service Centers**

For a complete listing of **Spellman's** Global Service facilities please go to:  
<http://www.spellmanhv.com/customerservice/service.asp>